



**FINAL REPORT**

**AIC 18-1003**

**NEW TRIBES MISSION**

**P2-NTZ**

**Quest Kodiak 100**

**NOSE WHEEL SEPARATION ON LANDING**

**MIBU AIRSTRIP, MADANG PROVINCE**

**PAPUA NEW GUINEA**

**09 AUGUST 2018**

## **About the AIC**

The Accident Investigation Commission (AIC) is an independent statutory agency within Papua New Guinea (PNG). The AIC is governed by a Commission and is entirely separate from the judiciary, transport regulators, policy makers and service providers. The AIC's function is to improve safety and public confidence in the aviation mode of transport through excellence in: independent investigation of aviation accidents and other safety occurrences within the aviation system; safety data recording and analysis; and fostering safety awareness, knowledge and action.

The AIC is responsible for investigating accidents and other transport safety matters involving civil aviation, in PNG, as well as participating in overseas investigations involving PNG registered aircraft. A primary concern is the safety of commercial transport, with particular regard to fare-paying passenger operations.

The AIC performs its functions in accordance with the provisions of the PNG Civil Aviation Act 2000 (As Amended), Civil Aviation Rules 2004 (as amended), and the Commissions of Inquiry Act 1951 (as amended), and in accordance with Annex 13 to the Convention on International Civil Aviation.

The object of a safety investigation is to identify and reduce safety-related risk. AIC investigations determine and communicate the safety factors related to the transport safety matter being investigated.

It is not a function of the AIC to apportion blame or determine liability. At the same time, an investigation report must include factual material of sufficient weight to support the analysis and findings. At all times the AIC endeavours to balance the use of material that could imply adverse comment with the need to properly explain what happened, and why it happened, in a fair and unbiased manner.

## **About this report**

The Papua New Guinea Accident Investigation Commission (AIC) was informed of the accident on the morning of 9 August 2018. The initial information indicated a propeller strike and as that does not constitute an accident in accordance with ICAO Annex 13 Standards, no AIC investigation was proposed. The AIC subsequently received a report detailing substantial damage to the propeller, engine, nose landing gear, and the associated airframe. The AIC immediately commenced an office investigation. The operator assisted the AIC's investigation, and the Australian Transport Safety Bureau provided materials failure analysis assistance.

This Final Report was produced by the AIC, PO Box 1709, Boroko NCD, Papua New Guinea.

The report is based upon the investigation carried out by the AIC, in accordance with *Annex 13* to the *Convention on International Civil Aviation*, the *PNG Civil Aviation Act 2000 (as amended)*, and the *AIC Investigation Policy and Procedures*. It contains details of *Safety Action* by the Rural Airstrips Agency and New Tribes Mission (PNG) Ltd., to address safety concerns identified following the accident.

# Aircraft bogged during landing roll - Nose landing gear failure

## Occurrence details

On 9 August 2018 local (8 August 2018 UTC), a Quest Kodiak 100 aircraft, registered P2-NTZ, owned and operated by New Tribes Mission (NTM), was flown from Goroka, Eastern Highlands Province, to the newly built Mibu airstrip in Madang Province.



**Figure 1: Showing the track flown Goroka to Mibu**

The purpose of the flight was for the first landing at the newly constructed Mibu airstrip. There were two NTM pilots on board; a pilot in command (PIC) and an observer pilot.

At about 23:32 UTC<sup>1</sup>, during the landing roll, the aircraft's nose wheel sank into a soft patch on the strip surface. The aircraft came to an abrupt stop and the nose-wheel fork fractured on both sides of the oleo attachment plate resulting in the nose-wheel and nose-wheel fork assembly separating from the oleo. The pilots, the sole occupants, were not injured.

The nose of the aircraft dropped as the fork separated from the oleo and dug further into the soft ground until the bottom of the engine cowling was on the ground (See figure 2).

The PIC stated that he added power soon after touching down to maintain a 20kt speed up the 17% slope towards the end of the strip. The engine and propeller, under significant power, were substantially damaged as they impacted the ground.

<sup>1</sup> The 24-hour clock is used in this report to describe the local time of day, Local Mean Time (LMT), as particular events occurred. Local Mean Time was Coordinated Universal Time (UTC) + 10 hours.

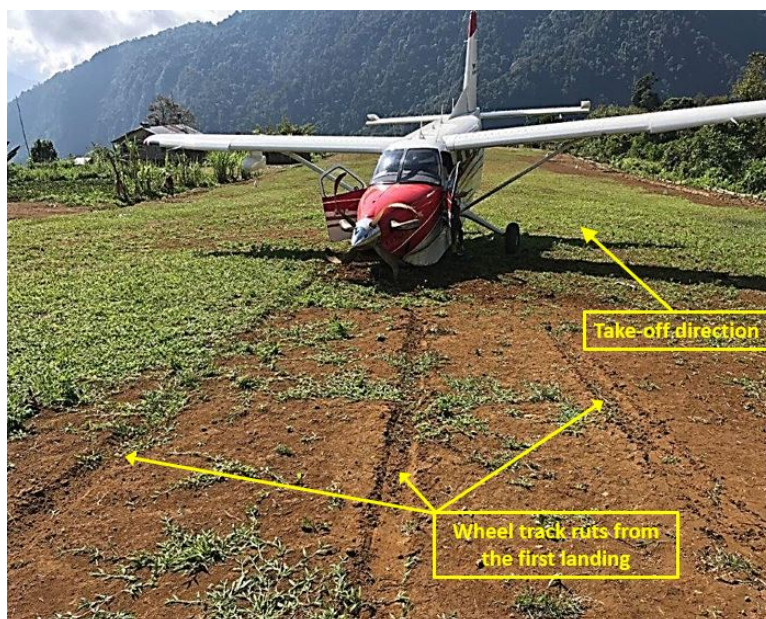

**Figure 2: P2-NTZ at Mibu Airstrip showing wheel tracks in strip soft surface**

The pilots reported that earlier that day they had received a strip report and learned that the Mibu Airstrip was dry and suitable for a landing. On arrival over the Mibu Airstrip the PIC flew the aircraft down the strip in the take-off direction to conduct an aerial inspection of the strip surface. The pilots subsequently reported that they did not observe any standing water, mud or cracks on the strip surface. They then conducted two circuits terminating in go-arounds for approach profile planning.

The first landing from the third approach and the subsequent takeoff were completed successfully. However, the pilots reported that they both noted two soft spots during the landing roll and that the aircraft decelerated quickly, and some extra power was needed to continue momentum up the hill. The subsequent takeoff was normal and the aircraft became airborne prior to that soft area.

During the next landing roll the aircraft's nose wheel sank into the soft surface of the strip and became bogged. Subsequent substantial damage included the nose-landing gear, propeller, engine and cowling.



**Figure 3: View of P2-NTZ showing the ruts in the soft strip surface from the first landing**

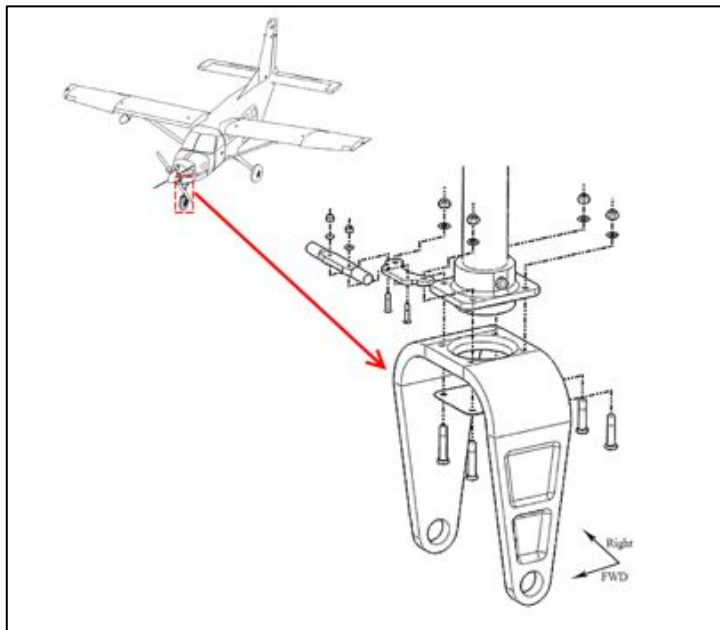

**Figure 4: Nose wheel and fork assembly in bog hole      Figure 5: Propeller assembly**

During July 2018, NTM personnel accompanied by a Geologist from the Rural Airstrip Agency (RAA) had flown to Mibu Airstrip by helicopter and conducted a detailed inspection of the strip. The Geologist's report included that drainage needed to be constructed on both sides of the strip. Continuous [water runoff] flow has the potential to cause erosion inwards onto the strip. Sub-surface strength needs further work to strengthen it. The report provided brief examples of how that could be achieved. The report also stated that the surface can be intermixed with sand or gravel to provide some traction, cohesion, strength and durability.

### **Quest Aircraft Service Bulletin**

On 2 June 2018 Quest Aircraft issued a Mandatory Services Bulletin SB18-01 for the Nose Landing Gear (NLG) Inspection for the Fork (Figure 6) for the Primary Inspection area as (Figure 7), top and bottom plate as per Field Services Instruction (FSI) (FSI-147)



**Figure 6: Diagram of nose-wheel fork and oleo attach plate  
(Source Quest Aircraft)**

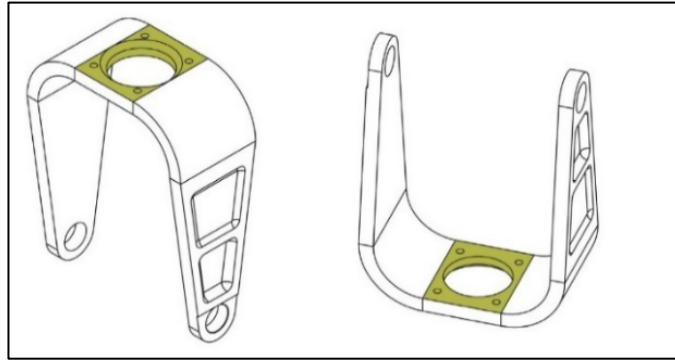

**Figure 7: Primary Inspection Area (Highlighted)**  
(Source Quest Aircraft)

The SB required an initial inspection using the procedures described in FSI-147 by removing the Type A NLG Fork and performing a non-destructive testing (NDT) inspection of the NLG Fork for cracks in accordance with (IAW) FSI-147.

The aircraft, P2-NTZ, serial number (S/N) 100-0118 fell within the affected S/N's 100-0001 through 100-0217 that were delivered with the NLG Fork P/N 100-410-7001 (identified as a "Type A" NLG Fork). Those forks were subject to inspections in accordance with SB18-01. Aircraft with subsequent serial numbers were delivered with the improved NLG Fork P/N 100-410-7013 (identified as a "Type B" NLG Fork) and were not affected.

The SB required replacement of the NLG fork before further flight if cracks were detected during the NDT inspection. For aircraft with serial numbers 100-0001 through 100-0217, replacement of the Type A NLG fork with an improved Type B NLG fork terminates the repetitive inspections of the NLG fork.

The investigation reviewed the NTM maintenance documentation that showed that an NDT inspection had been carried out on 20 June 2018 for the initial inspection in accordance with FSI-147. During the accident the nose landing gear fork fractured as described by the aircraft manufacturer in FSI-147.

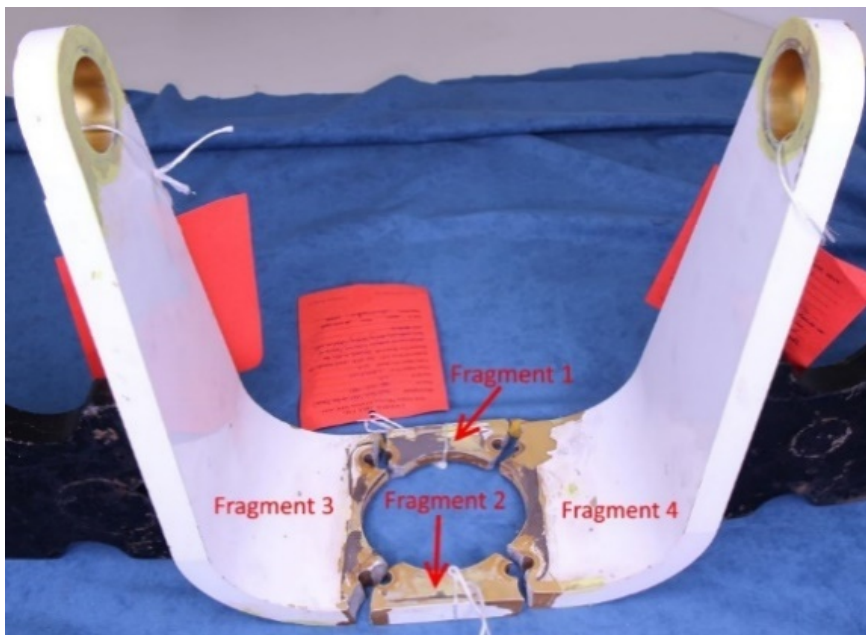

**Figure 8: Fragment pieces of the NTZ nose-wheel fork**  
(Source ATSB)

The AIC sent the fractured nose landing gear fork assembly to the Australian Transport Safety Bureau in Canberra, Australia for materials failure analysis in the ATSB's Engineering Laboratory. The ATSB report stated:

*In order to determine the causes of the accident, a material analysis was performed by ATSB, followed by a detailed study of the fracture's surface both visually and using optical and scanning electron microscopies and NDT confirmation. It was observed that stress cracks developed in the vicinity of the bolted holes, which work as supporting connections, on the top and bottom plates of the nose wheel fork and, as such, it can be concluded that the referred area was subjected to stresses originating and propagating cracks in the material that was highlighted in the Mandatory SB 18.1 that was issued by Quest aircraft. This cracking is characteristic of the existence of overstress concentration areas.*

*Fracture morphology suggested an overstress condition in every instance. Mostly brittle fractures were observed on all surfaces. Ductile fracture mode was also present. Some fractures exhibited a 45° shear lip, indicative of failure due to an overstress condition. No evidence of pre-existing damage was observed on any surface.*

*There is no evidence of pre-existing damage observed on the fork, and all of the fractures appeared to be a result of overstress.*



**Figure 9: Microscopic view of fracture surface arrow points to shear lip**  
(Source ATSB)



**Figure 10: Microscopic view of fracture surfaces**  
(Source ATSB)

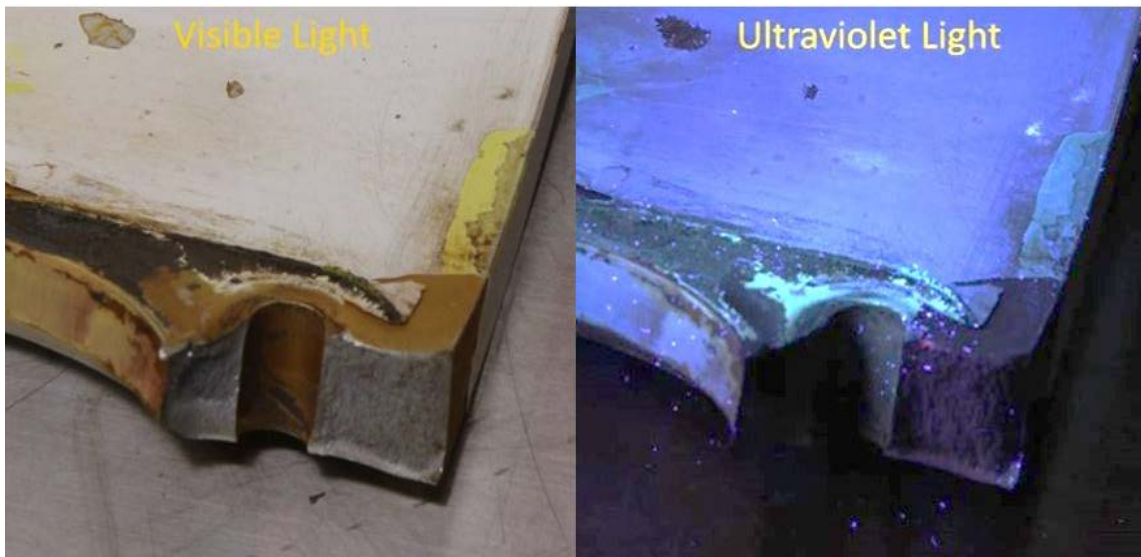

**Figure 11: Bolt hole fracture surface under visible light and ultraviolet light showing evidence of fluorescent penetrant (Source ATSB)**

### **PNG AIC comment**

The AIC determined that during the landing roll following the first touchdown, the aircraft decelerated quickly as the aircraft passed through two soft areas on the strip. Given it was the first landing on a newly constructed strip, it would have been prudent for the pilots to have conducted a visual inspection of the strip before further flight. Figure 2 clearly shows that the strip had soft areas leaving furrows on the strip from the first landing roll.

During the second landing roll the aircraft's nose wheel sank into the soft surface of the strip and became bogged.

The investigation found that there was evidence of non-destructive testing present in the form of fluorescent dye penetrant. The stripped paint and presence of fluorescent dye indicated that some NDT had been previously performed on the fork. That was indicative of compliance with the Quest Kodiak Service Bulletin.

There was no evidence of pre-existing damage within the fork.

All fractures observed in the nose landing gear fork were as a result of overstress.

The nose landing gear fork was determined to have fractured as a result of sudden impact overstress loads when the nose wheel sank into the soft ground and the aircraft abruptly stopped.



## **Safety action**

### **Rural Airstrips Agency (RAA) safety action**

On 5 September 2018 the AIC received the following safety action statement from the Rural Airstrips Agency:

*Following the accident at Mibu airstrip, the RAA has reviewed their internal procedures for producing and releasing technical airstrip reports. The procedures have now been amended to ensure both geological and civil engineering input is incorporated into the reports as applicable, and the reports are reviewed to ensure the technical input results in clear and concise recommendations that can be clearly understood by the general aviation public.*

### **New Tribes Mission (PNG) Ltd., (NTM) safety action**

On 6 September 2018 the AIC received the following safety action statement from New Tribes Mission (PNG) Ltd covering the steps NTM is taking following the accident:

- *Reviewing and revising the airstrip assessment procedure given in our international Operations Manual.*
- *Enhancing exercises in airstrip survey techniques.*
- *Establishing a more formal, structured approval process for the opening of new airstrips in bush locations, to include engagement with the senior persons team, completion of a risk assessment, etc.*

*While we work through those more procedural steps as we look to the future, we are also taking steps to ensure the Mibu airstrip is safe for further operations.*

*On 24 AUG 2018 NTM PNG sent two personnel into the Mibu airstrip via helicopter in order to perform a reassessment of the airstrip's surface and substrate strength using the procedure currently documented in our headquarter's international Operations Manual. The centre 9m of the airstrip was assessed along its full length. For the assessment the assessors used four rows of test points equally spaced at 3m along the length and width of the test area. The identified an area unfit for landing based on the surface and substrate strength. This area is an approximately 72m section of the airstrip, beginning 6m prior to the 8th edge marker from the approach end and stretching 6m past the 10<sup>th</sup> edge marker (markers placed at 30m intervals). The mishap aircraft came to rest in the middle of this section.*

*Based on the above assessment we have provided feedback to the local village leaders regarding the area marked out as unacceptable and have given them further guidance as to what needs to be done to rectify the unacceptable conditions. The people there have been very receptive to our input and have been working diligently to repair/improve the airstrip surface.*

*Related to the rework of the strip and the recommendation of the RAA was our direction to the Mibu people to move the edge markers in 10m from their current positions on the far edges of the 42m wide strip. This will provide the required overrun/excursion area outside the markers and allow the people to focus their current efforts and long-term maintenance activities on the critical area of the airstrip.*

*Additionally, we have engaged the RAA in dialogue regarding some questions we have now as we reflect on the report and ways we could improve the communication of data and potential areas of concern in the future so those making the go/no-go decision clearly understand the information available to them and may take appropriate action as necessary.*

### **PNG AIC comment on safety action**

The AIC has reproduced these Safety Action Statements in order that they may assist other communities that are building rural airstrips to better understand the safety issues associated with airstrip construction.

## General Details

Date and time:	8 August 2018 23:32 UTC	
Occurrence category:	Accident	
Primary occurrence type:	Aircraft Nose wheel bogged with fork broke off with the wheel	
Location:	Mibu Airstrip	
	Latitude: 5° 48' 39" S	Longitude: 146° 22' 24" E

## Crew details

Nationality	USA
Licence type	ATP (PNG)
Licence number	P22077
Total hours	9,563
Total hours in Command	9,272
Total hours on type	1,031

## Aircraft Details

Aircraft manufacturer and model:	Quest Aircraft Kodiak 100	
Registration:	P2-NTZ	
Serial number:	100-0118	
Engine manufacturer and model	Pratt & Whitney Canada PT6A-34	
Engine serial number	PCE-RB0780	
Propeller manufacturer and model	Hartzel HC-E4N-3P	
Propeller serial number	HH4907	
Type of operation:	Private flight. Newly constructed airstrip proving flight	
Persons on board:	Crew: 1 PIC	Passengers: 1 Pilot observer
Injuries:	Crew: Nil	Passengers: Nil
Damage	Nose landing gear fork fractured and separated from oleo; propeller destroyed; engine and cowling substantially damaged.	

**Approved**



**Hubert Namani, LLB**  
*Chief Commissioner*

14 January 2019